

DAC and Op Amp Generate Variable Negative Control Voltage

This design idea describes a simple circuit to generate a programmable negative control voltage. It takes the output of a single supply digital-to-analog converter (DAC) and produces a variable negative voltage. The DAC output from 0V to +2.5V is converted to 0V to -5V at the output.

Early digital-to-analog converters (DACs) were designed with standard R-2R ladders, and produced a negative output voltage. These early DACs (such as the MAX7837/MAX7847 and MAX523) require both a positive and a negative supply rail to accommodate their negative output. With the transition to single-supply integrated circuits, however, many modern DACs now operate with a single supply rail and an inverted R-2R ladder. The inverted R-2R ladder produces a positive output voltage.

Despite the popularity of single-supply ICs, some applications still require a negative control voltage. One solution for this purpose is a modern, inverted R-2R ladder DAC and op amp (Figure 1). When compared with older DACs containing standard R-2R ladders, this approach offers lower supply voltages, higher speed, and smaller packages.

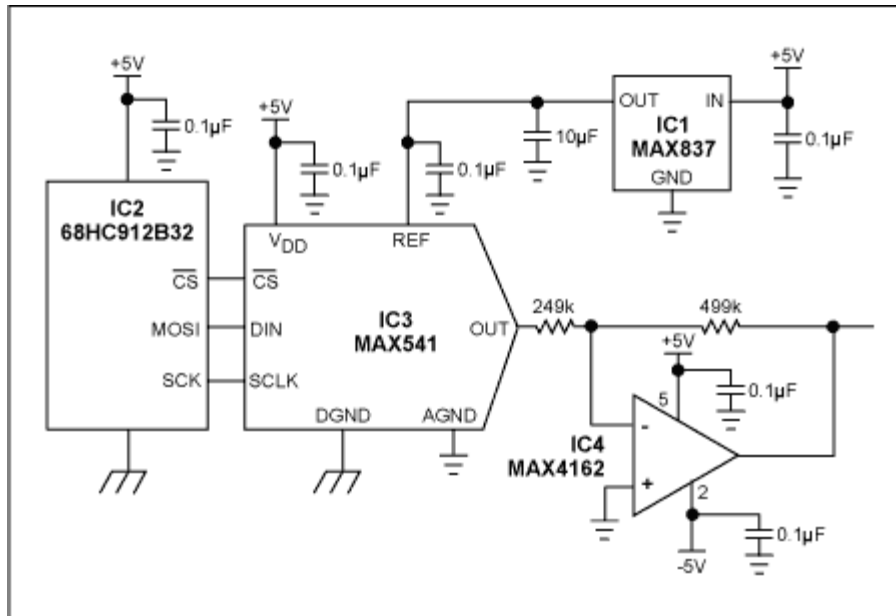

Figure 1. This compact circuit enables microcontroller IC2 to generate a variable negative voltage.

The DAC (IC3), operating with a 2.5V applied reference voltage from IC1 and driven by microcontroller IC2, produces an output swing from 0V to 2.5V. Op amp IC4 inverts and amplifies this output to produce a 0V to -5V output. For test purposes, a [software routine](#) enables the microcontroller to generate a 0V to -5V triangle-wave output.

A similar version of this article appeared in the December 6, 2001 issue of *EDN* magazine.

MORE INFORMATION

MAX4162: [QuickView](#) -- [Full \(PDF\) Data Sheet \(400k\)](#) -- [Free Sample](#)

MAX541: [QuickView](#) -- [Full \(PDF\) Data Sheet \(248k\)](#) -- [Free Sample](#)

MAX542: [QuickView](#) -- [Full \(PDF\) Data Sheet \(248k\)](#) -- [Free Sample](#)

MAX837: [QuickView](#) -- [Full \(PDF\) Data Sheet \(62k\)](#) -- [Free Sample](#)